

SOLAR T

PORTABLE TEMPERATURE CALIBRATOR 200/1200°C



The new **SOLAR T** are portable thermostatic calibrators for laboratory and field testing of temperature, thermocouples and Pt 100 sensors. They consist of a tubular vertical well with an internal ceramic element to isolate electrical parts and an interchangeable equalising block.

The equalising block, whose large size suits the external dimensions, ensures a proper heat transmission as well as optimal stability and uniformity values; its interchangeability makes it possible to test sensors of various length, with diameters ranging from 1 mm up to 25 mm.

The calibrators are equipped with a counter-current forced air cooling system which keeps at a low temperature the upper part of the well; this system enables to check even very short probes, without heating the connecting head or the handgrip.

The new **SOLAR T** series of calibrators is equipped with an innovative touch-sensitive display, where the various icons are graphically displayed, making it easier to select different instrument settings.

They are also equipped with a new 32-bit PID microprocessor-based controller with resolution up to 0.001°C, unit setting in °C °F and K, programming of ascent/descent ramps and storage of the thermostats operative temperature.

The **SOLAR T** are equipped with B type USB serial interface to operate in automatic mode connected to the PC by means of the Aq2Sp2 software which is capable to automate control procedure and allows to print reports, so they are easily traceable in compliance with ISO9000 standards.

APPLICATIONS:

- Control and calibration of temperature sensor, in the laboratory and in the field, in accordance with ISO 9000 standards
- Control of thermostats
- Automatic computer-controlled calibrations

MAIN CHARACTERISTICS:

- Operating range 200 (392°F)÷1200°C (2192°F)
- 2 different models
- High stability and precision
- TOUCH SCREEN Display
- Display resolution up to 0.001
- Light weight and compactness
- Automatic ramp function
- USB connection
- Counter-current forced air cooling system
- High depth of immersion
- Large diameter inserts
- Inserts with different hole patterns available
- keyboard calibration

tempcontrol



GIUSSANI

TESTING
EXPERTISE

SOLAR T

The solar has been in production since 1995 and has been considerably improved over the years, the current version is much more compact while retaining the same insert size and ensuring high thermal insulation even at the highest temperatures.

SOLAR T are also available in the **3I version**, in which the instruments are equipped with an acquisition card having three configurable inputs to be able to connect all types of sensors:

- EXT and REF to be able to connect thermocouples type B, E, J, K, N, R, S, T and RTDs type PT100, PT1000
- ANALOG for probes with 0-10V or 4-20 mA output

The REF input is provided for the reference sample probe, thus obtaining a complete calibration system which can be certified by Accredia centres, in compliance with ISO 9000 regulations.

The EXT input is provided for probes that are being tested; hence, the instrument can display the temperature of the well, the temperature of the sensor to be checked and the temperature of the reference sample probe, at the same time.

SOLAR +T

It is the new model, allowing operation up to 1200 °C, for control and verification of ultra-high temperature probes.

The design of this calibrator is derived from the evolution of the **SOLAR T** upgraded for use at an effective 1200 °C. It employs an extremely high temperature heating element for extended use.

COUNTER-CURRENT FORCED AIR COOLING SYSTEM

Both models are equipped with a counter-current forced-air ventilation system that keeps the temperature of the upper part of the calibrator very low. This solution allows the connection head of the probes under test to be kept very close to room temperature even for very short probes. It also ensures high safety for the operator because the temperature of the upper grid remains very low.

The attached photo shows a thermocouple probe in a SOLART oven at 1000°C the temperature of the connection head detected by means of an optical pyrometer is 37.7°C, very close to the room temperature. This test confirms the excellent

The calibrator is designed to maintain high insulation even at the highest temperatures. The standard equipment includes a ceramic insert with 4 holes DN 4.8/6.4/9.5/12.8 mm.

An Inconel insert with the same holes is also available for applications requiring a better axial uniformity.

It is not possible to have the 3I version.

insulation of both SOLART models.

In the photo below: temperature of thermocouple heads being tested at 1000°C

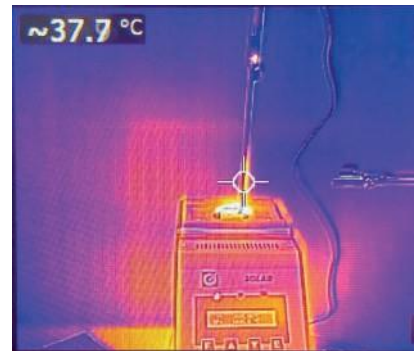

Accessories

A wide range of inserts is available for testing various types of probes from diameter 1 mm up to 25 mm (for the SOLAR T model).

The standard equipment includes for both furnaces a ceramic insert with 4 holes (Photo 1).

In addition, Inconel 600 inserts with the same hole pattern as the ceramic inserts are available for both models, as well as Inconel 600 inserts to be drilled according to specific requirements (Photo 2, Photo 3).

For the SOLAR T a ceramic insert with a central hole of 26 mm diameter is available allowing Inconel 600 adapters with a central hole and with external slots to be inserted according to design (Photo 7).

The inserts have top insulators with the same holes for proper isolation of the calibration zone.

A tweezer for insert removing is also provided (Photo 5, Photo 6).



7

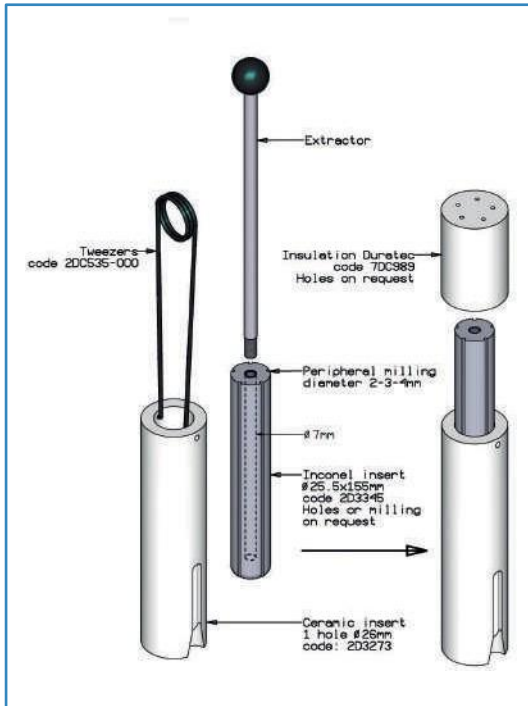

Specifications	SOLART+	SOLAR+T
Temperature range*	200°C -1100°C	200 -1200°C
DISPLAY	SCREEN TOUCH	
Display accuracy full temperature range**	±3°C	
Units of measure	°C/°F/K	
Display resolution	0.1°/ 0.01°/ 0.001° C	
Mean heating time	from Tamb to 1000°C	60 minutes
Mean cooling time	from 1000°C to 100°C	330 minutes
Stability	±0.05°C	
Axial Uniformity from 0 to 40 mm ceramic insert at 1000°C	3.6°C ±0.3	1.5 °C ±0.8
Axial Uniformity from 0 to 40 mm Inconel 600 insert at 1000°C	±1°C	±0.5 °C
Hole diameter	44 mm	35 mm
Hole depth	220 mm	210 mm
Insert material***	ceramics	
Switch test, voltage	On/Off 4.5VDC	
Adjustable ramp function	from 0.1°C/min	
Pc interface	B type USB	
External probes	Pt100 at 3/4 wires, Pt1000 Thermocouples J,K,N,R,S,E,T,B Sensor with 0-10 V or 4-20 mA	/
Automatic calibration	on 5 points	
Operating voltage	115 or 230 VAC	230 VAC
Electric power	900 W	
Calibrator size	170x330x450 mm	160x350x385 mm
Calibrator with standard equipment	12 kg	11.5 Kg
The achievement of stabilization is confirmed by an audible signal and LED, the calibrator is stable when the read temperature remains in a range of ±0.2°C for 6 minutes		

* values measured at room temperature 20°C

** temperature deviation between the display and the reference probe

*** INCONEL on demand

Touch Display



Touch-sensitive display with graphic visualisation of the various functions allowing the various functions to be activated intuitively without having to consult the user manual.

The new 32-bit microprocessor-based PID controller allows a resolution down to 0.001 °C

Aluminium rigid case

Code: 2D2240

Dimensions: 410x320x510 mm

Weight: 6.00 Kg

Packaging dimensions:
500x370x600 mm



Sturdy aluminium case that provides maximum safety for carrying the instrument.

Aluminium trolley

Code: 2FLIPULSAR80CASE

Dimensions:550x320x430 mm

Weight: 9.350 Kg

Packaging dimensions:
430x320x550 mm



Practical and sturdy aluminum trolley useful and functional for safe and convenient transportation of the calibrator and accessories.

SOLAR T

STANDARD EQUIPMENT:

- SOLART calibrator
- **2D3274:** Ceramic equalizing block DN 44X175 mm at 4 holes DN 7/9/11/13,5 mm, with top insulation
- Electric power cable
- Kit of fuses
- Thermostat connection cables
- Instruction manual
- Test report
- Tweezers for insert removing
- USB serial interface
- Kit of clamp connection (only 3I version)

ACCESSORIES ON DEMAND:

- **2D3345:** INCONEL Blind Insert DN 25.5 mm
- **2DC896:** INCONEL 600 Blind Insert with customizable holes
- **2D3360:** INCONEL Insert with side hole
- **2D3622:** INCONEL 600 black body
- **3D1275:** Sample probe TCK
- **3D1260:** Sample probe TCS
- **CERTI-SOLAR:** Accredia Certificate (only 3I VERSION) obtained with a sample probe connected to SOLART
- USB cable
- Software Aq2Sp2
- **2D2240:** Aluminium case
- **2D3273:** Ceramic equalizing block with 1 hole DN 26 mm
- **2FLIPULSAR80CASE:** Aluminium Trolley

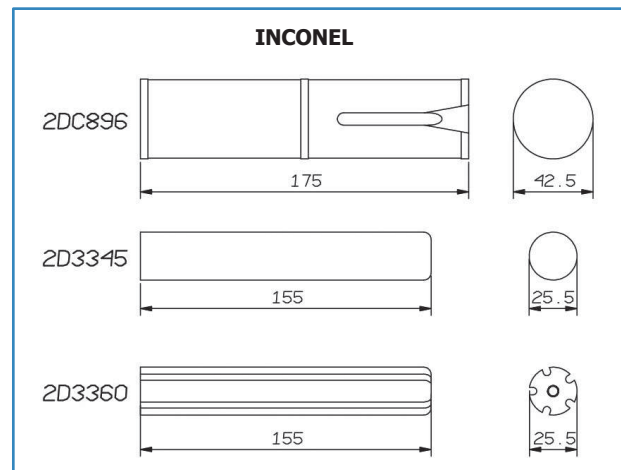
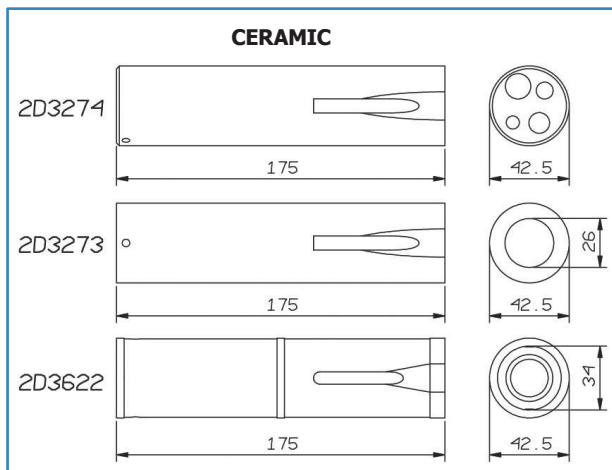

SOLAR+T

STANDARD EQUIPMENT:

- SOLAR+T calibrator
- **2D4019:** Ceramic equalizing block DN 34x160 mm with 4 holes DN 4.8/6.4/9.5/12.8 mm, with top insulation
- Electric power cable
- Kit of fuses
- Thermostat connection cables
- Instruction manual
- Tweezers for insert removing

ACCESSORIES ON DEMAND:

- **2D4499-002:** INCONEL 600 Insert With 4 holes DN 4.8/ 6.4/ 9.5/ 12.8
- **7D4072:** top insulator with standard hole
- **2DC896:** INCONEL 600 blind insert
- **7DC989:** top insulator with special hole
- **2D2240:** Aluminium rigid case
- **2FLIPULSAR80CASE:** Aluminium Trolley

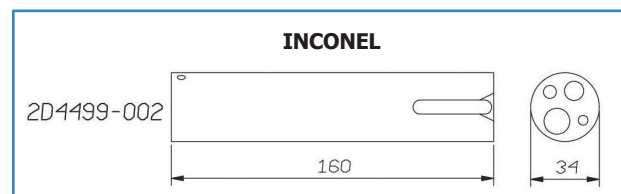
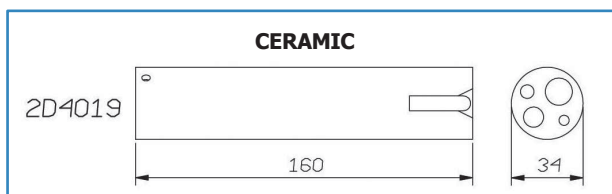

How to order:

Standard Version

SOLART-00-1

115V. 50/60 Hz

SOLART-00-2

SOLAR+T-00-2

230V 50/60 HZ

Version with 3 configurable input

SOLART-3I-1

115V. 50/60 HZ

SOLART-3I-2

230V 50/60 HZ



CERTIFICATION:

All instruments are supplied with final testing, stability and accuracy report traceable to Accredia standards.



GIUSSANI S.r.l.

Via dei Crederi, 411
24045 Fara Gera d'Adda (BG) - Italy
Tel.: 0363/399019 - Fax.: 0363/398725

tempcontrol