

novasens Infrared Sensor IR502G

At a glance

- Detection of small measurement spots over large measuring distances
- Quality, moisture-resistant germanium optics
- 3 m sensor cable, extendable up to 40m
- Robust and inured sensor housing
- Compact design



Specifications

| | |
|--|---|
| Measuring range / Field of application | -40°C to +1000°C Temperature Measurement System novasens 2050 0-250% Hotmelt Control System novasens 2000 |
| Spectral range | 8- 14 µm |
| Emissivity correction | 1,0 to 0,1 adjustable on controller |
| Dimensons | Length 62 mm x 18 mm diameter with M18x1 thread |
| Permissible moisture | 95% not condensing |
| Permissible ambient temperature | -20°C to +50°C |
| Distance to measuring spot | 100 mm : 2 mm |
| Accuracy | +/- 1% of reading |
| Repeat accuracy | 0,5°C (0-100°C), 1,0°C (over 100°C) |
| Reaction time | 60 ms |
| Resolution | 1/10°C |
| Outputs | 0-20 mA, 4-20 mA, 0-10VDC selectable on controller |
| Weight | 170 Grams (sensing head with 3m cable including plugs) |
| Protection class | IP64 |
| Delivery scope | Sensing head with 3 m cable including plugs and mounting screws |
| Conformity | RoHS-conformity |
| Model | 0200231 |

The sensor works as a part with the complete Infrared Temperature Measurement System novasens 2050 or the Hotmelt Control System novasens 2000.

Dimensions

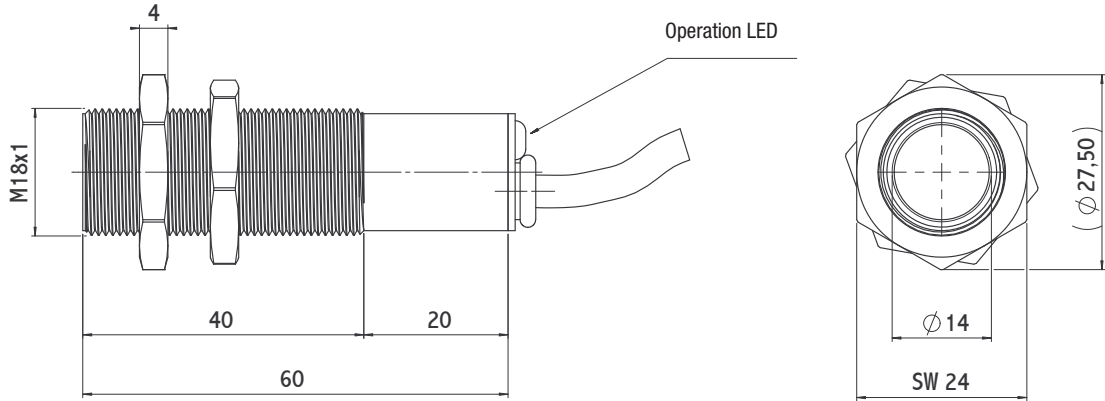

Optical Specifications

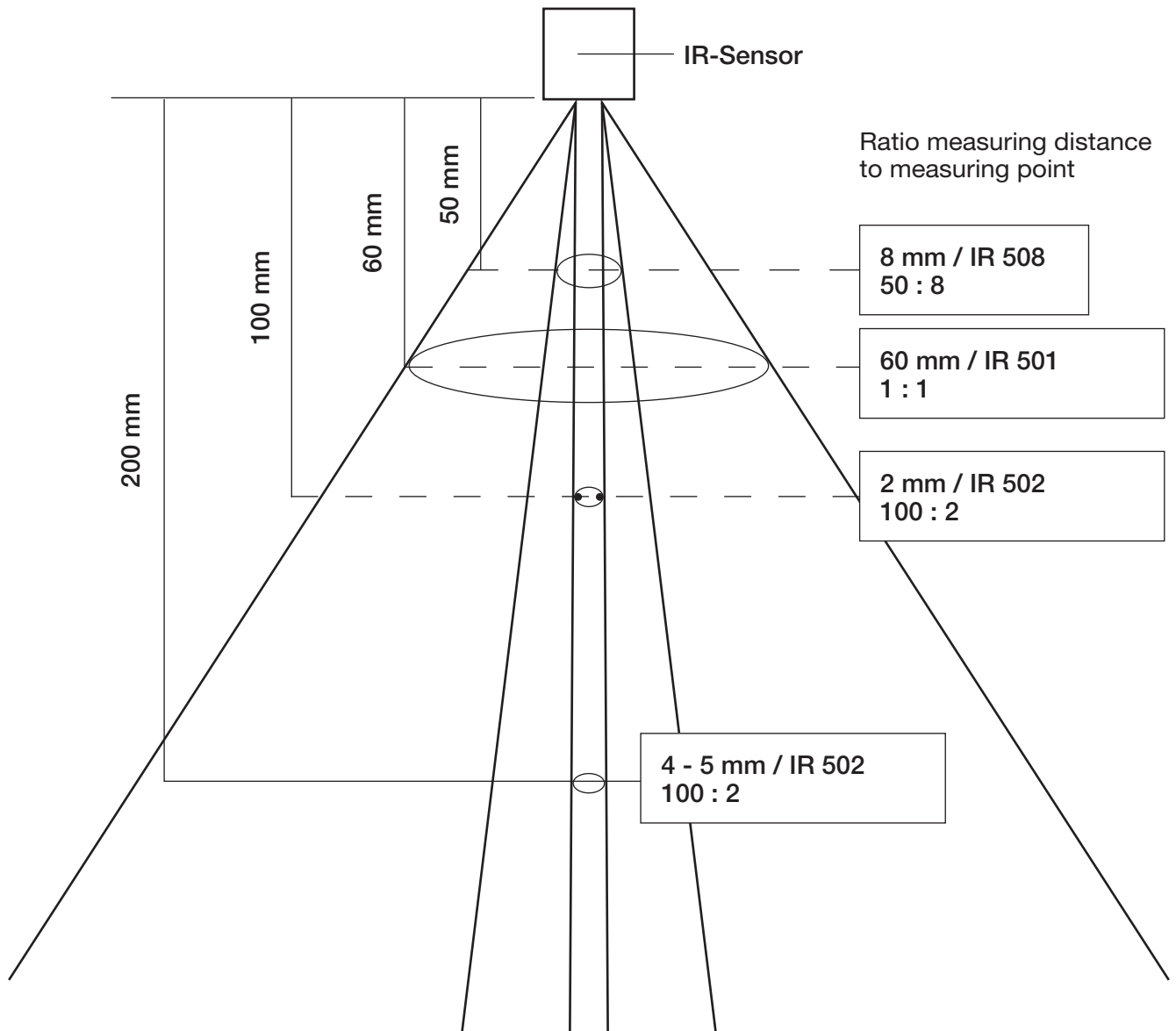

Variants and Options

IR502GAC



For use in hot or dirty environments. Measuring distance to spot and sensor size as IR502G with additional compressed air supply for air cooling and lens cleaning

ArtNr. 0200236

IR502GACV40



Very robust sensor for use in very hot or dirty environments. Air cooling and lens cleaning by compressed air. 40 mm additional tube against contamination and interference

ArtNr. 0200241

IR508G



Data as IR502G
Distance / spot 50:8
Example: measuring distance 50 mm = 8 mm spot size

ArtNr. 0200209

Water cooled sensor housing



For use in very hot ambient temperatures, or directly on a heat source. Attachment with rotatable T-piece for water supply, screw for all sensing heads

ArtNr. 0200239

Sensor cable extension



Including plugs, per meter

ArtNr. 0200225

Air filter F110



Replacement air filter F110 for all novasens sensors with air cooling and lens cleaning with compressed air

ArtNr. 0200215

IR502GS/IR508GS



Data as IR502G/IR508G, with faster response time of 5 ms

ArtNr. 0200232

IR502GW



Side cable output for sensors IR502G and IR508G, for use in confined areas.

ArtNr. 0200237

Specifications are subject to change.